

University of New Mexico
High School, Age Group, All Comers
Meet Information for 2011

Albuquerque Convention Center



GENERAL INFORMATION

ELIGIBLE PARTICIPANTS: Any high school, age-group, masters athlete is able to participate.

COMPETITION DATES: During 2011 meets will be held on Saturday, January 15; Saturday, January 22; Saturday, January 29

TIME CONSTRAINTS: The three meets will be held from 6:00pm - 9:00pm

REGISTRATION: Athletes can go to www.directathletics.com to register. Look for the correct meet when you are registering. High School/Open Meet #1 (January 15); High School/Open Meet #2 (January 22); High School/Open Meet #3 (January 29)

ENTRY DEADLINE: For high school, age group, all comers meets entry deadline is **noon** (MST) Thursday prior to the meet.

ENTRY FEES: Entry fee's are just that - an ENTRY fee, not a competition fee and no refunds can be given. Regular registration on Direct Athletics is \$6.00 per individual event paid by credit card at time of registration.

LATE ENTRY FEE: Late entries will be accepted (cash only) from 5:00pm - 5:45pm on meet day for \$10.00 PER EVENT. Registration will take place right behind tables at finish line inside arena.

INDOOR TRACK FACILITY: The UNM Indoor facility is located in the Albuquerque Convention Center and is a 200 meter, 60 degree banked Mondo track. The track has eight 42" sprint lanes which run down the center of the facility. The oval has six 36" lanes. The Pole Vault is contested inside the track oval and done from an elevated runway (Height 12" and Width 56") measuring 140' in length and covered by Mondo. There is one inner and one outer Long Jump pit with a 175' approach, and take-off boards at 2 meters (6' 1/2") and 4 meters (13'). Triple Jump approach is 145' and boards at are at 28' and 11 meters (36' 1"). The High Jump pits are moved onto the sprint straight for competition. The Shot Put/Weight Throw area is adjacent to the track and contested off a raised wooden circle.

WARM-UP AREA: For the indoor meets athletes will be able to warm-up on the outside of the track oval. Athletes are not permitted inside the oval if not competing directly in an event. Field event athletes are allowed to warm-up at the event site once the head referee has opened that area. There are several Mondo strips on the north end of the facility to warm-up.

COACHING AREA: Given the tight quarters indoors we request that all coaches stay outside the oval.

ATHLETE CHECK-IN: Check in at event site.

RESULTS: Following each event results will be posed on the board behind the timing booth which is outside the finish line area.

LOCKER ROOMS: There are no locker rooms facilities indoors at the Convention Center.

IMPLEMENT WEIGH-INS: Shots will be weighed in at the table adjacent to the throwing cage

FOOD POLICY: The Albuquerque Convention Center has a policy of NO food inside the track facility.

ADMISSION: There is NO charge for spectators at the high school, age-group, all-comers meets.

SPIKE POLICY: The Mondo Track facility is only able to accommodate 1/4" pyramid spikes. No athlete will be allowed to compete unless they have 1/4" pyramid spikes in their shoes.

MEET SCHEDULE

Long Jump (Boys & Girls)	Open Pit, 3 attempts	6:00pm - 8:00pm
Triple Jump (Boys & Girls)	Open Pit, 3 attempts	8:00pm - 9:00pm
Shot Put (Boys & Girls)	Open Pit, 3 attempts	6:00pm - 8:00pm
Pole Vault (Boys & Girls)	Continuous Bar Progression	6:00pm - 8:00pm
High Jump (Boys & Girls)	Continuous Bar Progression	7:00pm - 8:30pm

Running Events will run one after another on a rolling time schedule. In all running events girls will precede boys.

6:00pm	60 meter Hurdles (Girls - 33"; Boys - 39")
	60 meter Sprint
	1 Mile Run
	200 meter (1/15 & 1/29)
	800 meter
	400 meter (1/22)
	3200 meter (1/29)
	4 x 200 Relay (1/15 & 1/29)
	4 x 400 Relay (1/22)

FOR ANY QUESTIONS CONTACT
JIMMY BUTLER, MEET DIRECTOR
ASSISTANT TRACK & FIELD COACH - UNM
butljm02@hotmail.com

CHECK OUT GREAT COLLEIATE & PROFESSIONAL ACTION AT UNM'S HOME MEET

Saturday, January 15th - 10:00am

(featuring LSU, Cal-Irvine, New Mexico State, UTEP, NMSU, NM Highland)

Fri/Sat, January 21-22 (5:00pm - Fri; 10:00am Sat) Lobo Open

(featuring Alabama, Arizona, BYU, California, Miami (FL), NMSU, Northern Arizona Stanford, UNLV, Western State)

Fri/Sat, January 28-29 (5:00pm - Fri; 10:00am Sat) Cherry & Silver Invt.

(featuring Adams St., Arizona, Arizona St., Fresno St., Nevada, NMSU, NM Highland, Northern Arizona, San Diego St., UTEP, Western State)

Fri/Sat, February 4-5 (9:00am - Fri; 10:00am - Sat) New Mexico Invitational

(featuring Air Force, Arizona, Arizona St., Colorado St., Langston, NMSU, NM Highland, Sacramento St., San Diego St., UCLA, Utah St.)

Friday, February 11 (4:00pm) Don Kirby Invitational

(featuring Long Beach St., NMSU, Ohio State, San Diego St., Stanford, Texas, Texas Tech, Wyoming)

Th/Fri/Sat, February 24-26 Mountain West Conference Championship

Sat/Sun, February 26-27 USA Indoor Track & Field Championship

Fri/Sat/Sun, March 4-6 USA Indoor Masters Track & Field Championship

Fri/Sat, March 11-12 NCAA Divison II Indoor Track & Field Championship

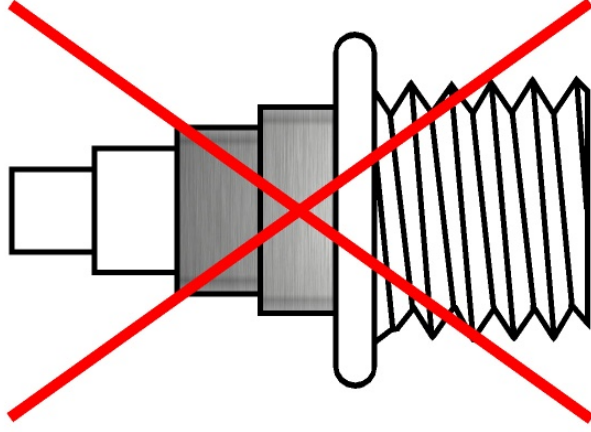

NO

**Christmas
Tree Spike
Pins**

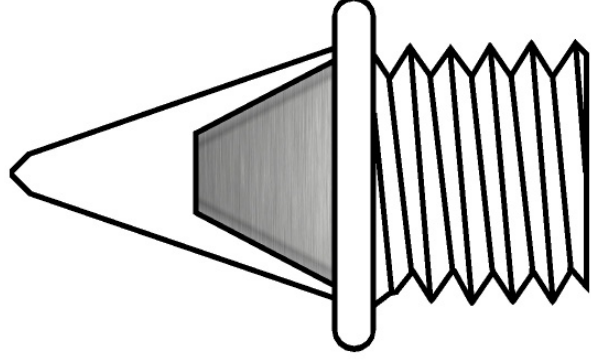

1/4"

Pyramid

Item #463A from
MF Athletics
800-693-6052

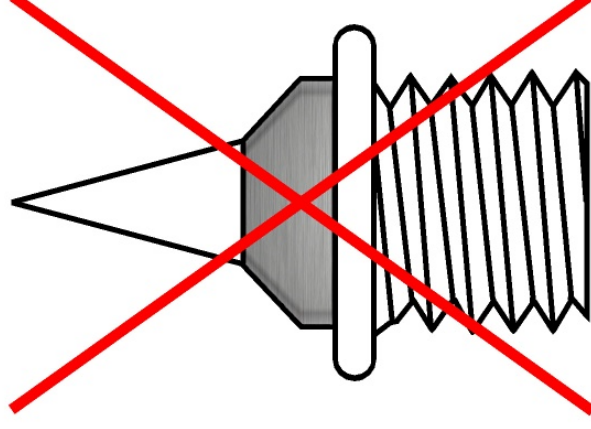

NO

**Needle
Spike
Pins**

